

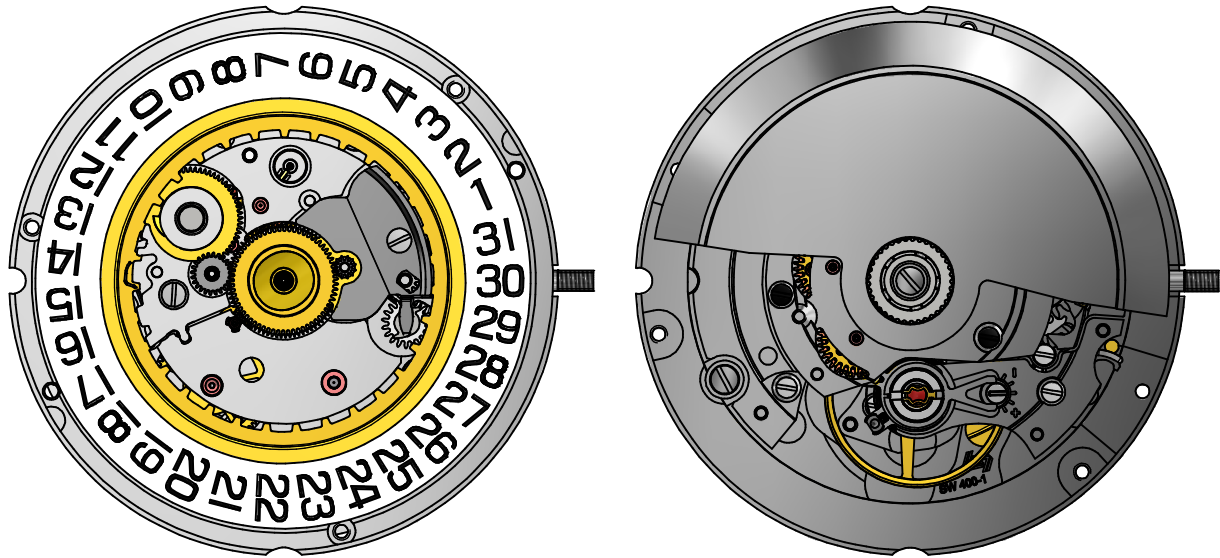

SELLITA

Le temps en mouvement



<p>SELLITA SW400-1 SWISS MADE</p>	
<p>Hauteur Höhe Height</p>	<p>4.67 mm</p>
<p>Diamètre d'encageage Gehäusepassungsdurchmesser Case fitting diameter</p>	<p>31 mm - 14'''</p>
<p>Fréquence Frequenz Frequency</p>	<p>28'800 A/h (4 Hz)</p>
<p>Réserve de marche Gangreserve Running time</p>	<p>38 heures</p>
<p>Nombre de rubis Anzahl Rubine Number of jewels</p>	<p>26</p>
<p>Angle de levée du balancier Hebungswinkel der Unruh Angle lift of balance</p>	<p>50°</p>

به سفارش دقت زمان تهران

Cette page est laissée vide intentionnellement en cas d'impression recto-verso.

Diese Seite wird absichtlich leer gelassen für den Fall, dass doppelseitig gedruckt wird.

This page has deliberately been left blank in case of double sided printing

Spécifications techniques - Technische Spezifikationen - Technical specifications

Forme et genre Form und Art Shape and type	Calibre rond, mouvement à ancre mécanique, remontage automatique intégré dans le mouvement. Rundes Kaliber, mechanisches Ankerwerk, integrierter Automatischeraufzug im Werk. Round caliber, mechanical lever movement, self-winding mechanism integrated in the movement.
Fréquence Frequenz Frequency	28'800 alternances par heure, 4 Hz 28'800 Halbschwingungen pro Stunde, 4 Hz 28'800 vibrations per hour, 4 Hz
Pierres Stein Jewels	26
Diamètre total Gesamtdurchmesser Overall diameter	31.6 mm
Diamètre d'encadrement Gehäusepassungsdurchmesser Case fitting diameter	31 mm
Hauteur Höhe Height	4.67 mm
Fonctions Funktionen Functions	Affichage par aiguilles : heures, minutes, secondes. Quantième à guichet Anzeige durch Zeiger: Stunden, Minuten, Sekunden. Datumanzeige im Fenster Display by means of hands: hours, minutes, seconds. Date display in window
Tige de remontoir Aufzugswelle Winding stem	3 positions : 1) Remontage manuel 2) Correction rapide de date 3) Mise à l'heure avec stop seconde. 3 Stellungen : 1) Handaufzug 2) Schnellkorrektur des Datums 3) Zeigerstellung mit Sekundenstopp. 3 positions : 1) Manual winding 2) Quick correction of date 3) Time setting with stop-second.
Platine et ponts Werkplatte und Brücken Main plate and bridges	Fabriqués en laiton Aus Messing hergestellt Made of brass
Masse oscillante Schwungmasse Oscillating weight	Masse monobloc en laiton et roulement à billes Monoblockmessingschwungmasse und Kugellager Monoblock oscillating weight of brass and ball bearing
Ressort de barillet Aufzugsfeder Barrel spring	Nivaflex
Moment de force Kraftmoment Moment of force	M ^{1/2} max: 11.86 N.mm M ²⁴ min: 8.83 N.mm
Moment de glissement Gleitmoment Sliding moment	Min. 12.21 N.mm Max. 16.57 N.mm

Remontage - Aufzug - Winding

Par tige de remontoir Über die Aufzugswelle With winding stem	Nombre de tours Umdrehungen Turns	Vitesse Geschwindigkeit Speed	Temps Zeit Time
Dispositif automatique monté Automatik-Mechanismus montiert Self-winding mechanism assembled	Min. 27	Max. 100 t/min	Max. 25 s
Dispositif automatique non monté Automatik-Mechanismus nicht montiert Self-winding mechanism not assembled	Min. 27	Max. 400 t/min	Max. 10 s
Par le dispositif automatique Über den automatischen Aufzug With the self-winding	Nombre de tours Umdrehungen Turns	Vitesse Geschwindigkeit Speed	Temps Zeit Time
Sur machine Chapuis (mouvement en marche) Auf Chapuis-Maschine (Werk in Betrieb) On Chapuis machine (movement in motion)	-	cycles/min 16 zyklen/min cycles/min	1h30
Sur Cyclotest (mouvement arrêté, tige tirée) Auf Cyclotest (Werk ausser Betrieb, Stellwelle gezogen) On cyclotest (stopped movement, stem pulled out)	1250	4 t/min	-

Assortiment - Hemmung – Assortment

Exécution – Ausführung - Range	Standard	Spécial (Elaboré)	Prémium (Top)	Chronomètre
Roue d'échappement Hemmungsrads Escape wheel	Acier, Plat poli, un biseau, inclinés polis, épilamée, Lubrifar Stahl, flachpoliert, 1 Abschrägung, polierte Hebungsfächen, epilamisiert, Lubrifar Steel, Flat polished, 1 bevel, polished inclinations, Epilame-coated, Lubrifar			
Ancre Anker Pallet fork	Acier, Plat poli, entrée bercée, renversements bercés Stahl, flachpoliert, Gabeleinschnitt abgerundet, Anschläge abgerundet Steel, flat polished, rounded-off lever-notch, rounded-up pallet cock			
Levées Herbelsteine Pallet stones	Rubis rouge, épilamées Roter Rubin, epilamisiert Red ruby, Epilame-coated			
Balancier Unruh Balance wheel	Nickel doré Nickel vergoldet Nickel gilt		Glucydur doré Glucydur vergoldet Glucydur gilt	
Amortisseur de chocs Stoßdämpfer Shock absorber	Novodiac		Incabloc	
Virole Spiralrolle Collet	Nivatronic			
Axe Unruhwellen Staff	Epilamé Epilamisiert Epilame-coated			
Angle de levée Hebungswinkel Lift angle	50°			
Raquetterie Rückersystem Regulator system	Avec dispositif de réglage fin Mit Feinregulierungsvorrichtung With fine timing device			
Positions Lagen Positions	CH, 6H	CH, 6H, 9H	CH, FH, 6H, 9H, 3H	
Marche moyenne Mittelwert Gang Average rate	0h	12 ±12 s/d	7 ±7 s/d	4 ±4 s/d
Ecart maxi toutes positions Max. Abweichung alle Pos. Max deviation all positions	0h	30 s/d	20 s/d	15 s/d
Isochronisme Isochronismus Isochronism	CH 0h-24h	±20 s/d	±15 s/d	±10 s/d
Amplitude max. Max. Schwingungsweite Max. amplitude	CH 0h	315°		
Amplitude min. Min. Schwingungsweite Min. amplitude	6H 24h	200°		

Complément du tableau Assortiment – Ergänzung zur Hemmungstabelle- Addition to the summary Assortment

(1)

Références pour mesure de marche - Referenzen für Gangmessungen - References to measure the rate

Repère max. (CH 0h) Abfall max. (CH 0Std) Adjusting max (CH 0h)	0.8 ms Standard & Elaboré 0.6 ms TOP & Chronomètre
Temps de stabilisation / Reprise de marche Stabilisationszeit / Wiederaufnahme des Ganges Stabilisation time / rate resumption	20 s Valeur conseillée Empfohlener Wert Recommended value
Temps d'intégration / mesure Integrationszeit / Messung Integration time / measuring	40 s Valeur conseillée Empfohlener Wert Recommended value

(2)

Les valeurs limites sont sujettes à interprétation : 95 % des pièces livrées par lot doivent se situer dans les marges indiquées.
Die Grenzwerte sind eine Frage der Auslegung: 95 % der in einer Lieferung enthaltenen Stücke müssen innerhalb der angegebenen Toleranzen liegen.
The limit values are subject to interpretation: 95 % of the pieces delivered in a lot must be within the specified limits.

(3)

Toutes les mesures se font sans calendrier en prise. Les contrôles à armage haut, désignés par 0 h, se font entre 1 et 3 heures après armage complet.

Für die Messungen darf sich der Kalender nicht im Eingriff befinden. Die Kontrolle bei Vollaufzug, angegeben mit 0 h, wird 1 bis 3 Stunden nach dem Aufziehen gemacht.

All check are made without the calendar in function. The check has to be done at full winding, referred to as 0 h, after 1 to 3 hours running.

(4)

Lors du contrôle des marches instantanées et des amplitudes, il faut impérativement tenir compte des imprécisions de mesure dues aux appareils, à la température et à la pression atmosphérique agissant sur les réglages.

Im Weiteren muss bei einer augenblicklichen Gang- und Schwingungsweitekontrolle unbedingt die momentane Einwirkung der Apparate bzw. der Raumtemperatur und des Atmosphärendrucks einbezogen werden.

When checking the instantaneous rate and the amplitudes, accuracy of the measurement tool, temperature and pressure acting on the settings must be considered.

(5)

Positions selon les normes NIHS Positionen nach den NIHS-Normen Positions according to the norms NIHS		Désignations courantes pour horlogers Gebräuchliche Bezeichnungen für Uhrmacher Common designations for watchmakers	
CH	Horizontale, cadran en haut	HH	Horizontale haut
	Horizontal, Zifferblatt oben	ZO	Zifferblatt oben
	Horizontal, dial up	DU	Dial up
FH	Horizontale, fond en haut	HB	Horizontale bas
	Horizontal, Zifferblatt unten	ZU	Zifferblatt unten
	Horizontal, dial down	DD	Dial down
6H	Verticale, 6 heures en haut	VG	Verticale gauche
	Vertikal, 6 Uhr oben	KL	Krone links
	Vertical, 6 o'clock up	PL	Positions left
9H	Verticale, 9 heures en haut	VB	Verticale bas
	Vertikal, 9 Uhr oben	KU	Krone unten
	Vertical, 9 o'clock up	PD	Position down
3H	Verticale, 3 heures en haut	VH	Verticale haut
	Vertikal, 3 Uhr oben	KO	Krone oben
	Vertical, 3 o'clock up	PU	Position up

Liste des fournitures –Bestandteilliste –List of components

Code article SELLITA	Nativité	Compatibilité		Code horloger		N° plan	Désignation	Designation	Bezeichnung
		SW200-1	SW400	Nouveau	Ancien				
010.020.00005	SW200-1	X	X	10.020	100	SW101492	Platine - SW200-1 - Garnie - Brute	Main plate - SW200-1 - Jewelled - Raw	Werkplatte - SW200-1 - Mit Steinen - Roh
010.041.00001	SW200-1	X	X	10.041	105	SW101646	Pont de barillet - Garni - Brut	Barrel bridge - Jewelled - Raw	Federhausbrücke - Mit Steinen - Roh
010.048.00001	SW200-1	X	X	10.048	110	SW101648	Pont de rouage - Garni - Brut	Train wheel bridge - Jewelled - Raw	Räderwerkbrücke - Mit Steinen - Roh
012.030.00001	SW200-1	X	X	12.030	1134	SW101659	Bâti du dispositif automatique - Garni - Brut	Automatic device mechanism - Jewelled - Raw	Automatik-Mechanismus - Mit Steinen - Roh
012.051.00001	SW200-1	X	X	12.051	1141	SW101662	Pont inférieur du dispositif automatique - Garni - Nickelé	Automatic device lower bridge - Jewelled - Nickel-plated	Untere Brücke für Automatik - Mit Steinen - Vernickelt
022.010.00284	SW400	X	X	22.010	1143	SW105354	Masse oscillante - Monobloc - Brute	Oscillating weight - Monoblock - Raw	Schwingmasse - Monoblock - Roh
010.058.00001	SW200-1	X	X	10.058	121	SW101655	Pont de balancier - Brut	Balance bridge - Raw	Uhrbrücke - Roh
010.057.00017	SW200-1	X	X	10.057	125	SW101651	Pont d'ancre - Garni - Nickelé	Pallet bridge - Jewelled - Nickel-plated	Ankerbrücke - Mit Steinen - Vernickelt
032.031.00001	SW200-1	X	X	32.031	1481	SW101691	Moblie de réduction	Reduction wheel	Reduktionsrad
032.033.00001	SW200-1	X	X	32.033	1482	SW101693	Moblie entraîneur de rochet	Ratchet wheel driving wheel	Mitnehmerad für Sperrad
022.040.00001	SW200-1	X	X	22.040	1497	SW101481	Roulement à billes - Acier - Nickelé galvanique	Ball bearing - Steel - Nickel galvanic	Kugellager - Stahl - Galvanisch vernickelt
032.037.00001	SW200-1	X	X	32.037	1535-1488	SW101697	Moblie d'inversion - (Roue à cliquets) - Monté	Reversing wheel - (Wheel with clicks) - Assembled	Umkehrad - (Rad mit Klinken) - Montiert
032.038.00001	SW200-1	X	X	32.038	1545-1530	SW101706	Moblie auxiliaire d'inversion - (Roue à cliquets) - Monté	Auxiliary reversing wheel - (Wheel with clicks) - Assembled	Hilfs-Umkehrad - (Rad mit Klinken) - Montiert
080.400.00001	SW200-1	X	X	80.400	161-163/1	SW101730	Tube de centre - L:2,50	Centre tube	Zentrumlagerrohr
093.030.00003	SW220-1	X	X	93.030	166	SW101768	Brde d'emboilage - Courte 3.4 (pliage haut)	Casing clamp - Short 3.4 (folded up)	Befestigungsplättchen - Kurz 3.4 (nach oben)
030.014.00001	SW200-1	X	X	30.014	201/1	SW101351	Moblie de grande moyenne - (Roue intermédiaire) - Monté	Great wheel - Assembled	Grossbodenrad - Montiert
030.025.00001	SW200-1	X	X	30.025	210	SW101317	Moblie de moyenne - Monté	Third wheel - Assembled	Kleinbodenrad - Montiert
030.027.00004	SW200-1	X	X	30.027	227-220	SW101347	Moblie de seconde - Monté - Aiguillage 2	Second wheel - Assembled - Hand fitting height 2	Sekundenrad - Montiert - Zeigenwerkshöhe 2
030.027.00005	SW200-1	X	X	30.027	227-220	SW101347	Moblie de seconde - Monté - Aiguillage 3	Second wheel - Assembled - Hand fitting height 3	Sekundenrad - Montiert - Zeigenwerkshöhe 3
030.027.00006	SW200-1	X	X	30.027	227-220	SW101347	Moblie de seconde - Monté - Aiguillage 4	Second wheel - Assembled - Hand fitting height 4	Sekundenrad - Montiert - Zeigenwerkshöhe 4
030.027.00007	SW200-1	X	X	30.027	227-220	SW101347	Moblie de seconde - Monté - Aiguillage 5	Second wheel - Assembled - Hand fitting height 5	Sekundenrad - Montiert - Zeigenwerkshöhe 5
030.027.00008	SW200-1	X	X	30.027	227-220	SW101347	Moblie de seconde - Monté - Aiguillage 6	Second wheel - Assembled - Hand fitting height 6	Sekundenrad - Montiert - Zeigenwerkshöhe 6
030.027.00009	SW200-1	X	X	30.027	227-220	SW101347	Moblie de seconde - Monté - Aiguillage 7	Second wheel - Assembled - Hand fitting height 7	Sekundenrad - Montiert - Zeigenwerkshöhe 7
030.027.00001	SW200-1	X	X	30.027	227-220	SW102556	Moblie de seconde - (sans seconde)	Second wheel - (without sec.)	Sekundenrad - (ohne Sec.)
031.083.00002	SW200-1	X	X	31.083	247-242	SW101348	Chaussée avec entraîneur - Montée - Aiguillage 2	Cannon pinion - Assembled - Hand fitting height 2	Minutenrohr - Montiert - Zeigenwerkshöhe 2
031.083.00003	SW200-1	X	X	31.083	247-242	SW101348	Chaussée avec entraîneur - Montée - Aiguillage 3	Cannon pinion - Assembled - Hand fitting height 3	Minutenrohr - Montiert - Zeigenwerkshöhe 3
031.083.00004	SW200-1	X	X	31.083	247-242	SW101348	Chaussée avec entraîneur - Montée - Aiguillage 4	Cannon pinion - Assembled - Hand fitting height 4	Minutenrohr - Montiert - Zeigenwerkshöhe 4
031.083.00005	SW200-1	X	X	31.083	247-242	SW101348	Chaussée avec entraîneur - Montée - Aiguillage 5	Cannon pinion - Assembled - Hand fitting height 5	Minutenrohr - Montiert - Zeigenwerkshöhe 5
031.083.00006	SW200-1	X	X	31.083	247-242	SW101348	Chaussée avec entraîneur - Montée - Aiguillage 6	Cannon pinion - Assembled - Hand fitting height 6	Minutenrohr - Montiert - Zeigenwerkshöhe 6
031.083.00007	SW200-1	X	X	31.083	247-242	SW101348	Chaussée avec entraîneur - Montée - Aiguillage 7	Cannon pinion - Assembled - Hand fitting height 7	Minutenrohr - Montiert - Zeigenwerkshöhe 7
031.083.00052	SW200-1	X	X	31.083	247-242	SW101362	Chaussée avec entraîneur - Borgne - Montée - Aiguillage 7	Cannon pinion - Blind - Assembled - Hand fitting height 7	Minutenrohr - Sackloch - Montiert - Zeigenwerkshöhe 7
031.046.00002	SW200-1	X	X	31.046	255-250	SW101349	Roue des heures - Montée - Aiguillage 2	Hour wheel - Assembled - Hand fitting height 2	Stundenrad - Montiert - Zeigenwerkshöhe 2

Code article SELLITA	Nativité	Compatibilité		Code horloger		N° plan	Désignation	Designation	Bezeichnung
		SW200-1	SW400	Nouveau	Ancien				
031.046.00003	SW200-1	X	X	31.046	255-250	SW101349	Roue des heures - Montée - Aiguillage 3	Hour wheel - Assembled - Hand fitting height 3	Stundenrad - Montiert - Zeigenwerkshöhe 3
031.046.00004	SW200-1	X	X	31.046	255-250	SW101349	Roue des heures - Montée - Aiguillage 4	Hour wheel - Assembled - Hand fitting height 4	Stundenrad - Montiert - Zeigenwerkshöhe 4
031.046.00005	SW200-1	X	X	31.046	255-250	SW101349	Roue des heures - Montée - Aiguillage 5	Hour wheel - Assembled - Hand fitting height 5	Stundenrad - Montiert - Zeigenwerkshöhe 5
031.046.00006	SW200-1	X	X	31.046	255-250	SW101349	Roue des heures - Montée - Aiguillage 6	Hour wheel - Assembled - Hand fitting height 6	Stundenrad - Montiert - Zeigenwerkshöhe 6
031.046.00007	SW200-1	X	X	31.046	255-250	SW101349	Roue des heures - Montée - Aiguillage 7	Hour wheel - Assembled - Hand fitting height 7	Stundenrad - Montiert - Zeigenwerkshöhe 7
033.020.00001	SW200-1	X	X	33.020	2566-2560	SW100654	Mobile entraîneur de l'indicateur de quantité - Monté	Date indicator driving wheel - Assembled	Datumanzeiger-Minehennrad - Montiert
091.440.00172	SW400	X	X	91.440	2557/1	SW105311	Indicateur de quantité - Brut	Date indicator - Raw	Datumanzeiger - Roh
091.440.00175	SW400	X	X	91.440	2557/1	SW105332	Indicateur de quantité - Fond Blanc, Décalque Noir - Guichet 3H	Date indicator - White background - Black print - Aperture 3 o'clock	Datumanzeiger - Weisses Hintergrund - Schwarzer Druck - Fenster 3 Uhr
091.440.00176	SW400	X	X	91.440	2557/1	SW105332	Indicateur de quantité - Fond Noir, Décalque Blanc - Guichet 3H	Date indicator - Black background - White print - Aperture 3 o'clock	Datumanzeiger - Schwarzer Hintergrund + Weisses Druck - Fenster 3 Uhr
053.200.00001	SW200-1	X	X	53.200	2566	SW101723	Correcteur de quantité	Date corrector	Datumkorrektor
053.026.00001	SW200-1	X	X	53.026	2570	SW101350	Commande du correcteur double	Double corrector operating lever	Schalthebel für Doppelkorrektor
053.080.00001	SW200-1	X	X	53.080	2576	SW101722	Sautoir de quantité	Date jumper	Datumraste
013.111.00001	SW200-1	X	X	13.111	2595	SW101663	Plaque de maintien du sautoir de quantité - Montée	Date jumper maintaining plate	Halleplatte für Datumraste
031.041.00001	SW200-1	X	X	31.041	260	SW101629	Mobile de minuterie - Monté	Minute wheel - Assembled	Wechselrad - Montiert
040.340.00002	SW200-1	X	X	40.340	300	SW101175	Flèche de raquette (supérieure)	Regulator pointer	Rückerstel
040.341.00001	SW200-1	X	X	40.341	300/6	SW101183	Tête de raquette (inférieure) - Montée	Regulator head - Assembled	Rückerkopf - Montiert
070.500.00001	SW200	X	X	70.500	3024	SW105370	Amortisseur (antichoc) empierré, à chasser, à portée, de balancier SUS - (Pont de balancier) INCA Réf.090.164.22.312/0-0	Jewelled shock-absorber, shouldered, to press in, for balance, TOP - (Balance bridge) INCA Réf.090.164.22.312/0-0	Stossicherung mit Stein, zum Einpressen, mit Auflage, für Unruh, OBEN - (Unruhbrücke) INCA Réf.090.164.22.312/0-0
070.500.00002	SW200	X	X	70.500	3024	-	Amortisseur (antichoc) empierré, à chasser, à portée, de balancier, SUS - (Pont de balancier) NOVO Réf.090.864.10/0-10	Jewelled shock-absorber, shouldered, to press in, for balance, TOP - (Balance bridge) NOVO Réf.090.864.10/0-10	Stossicherung mit Stein, zum Einpressen, mit Auflage, für Unruh, OBEN - (Unruhbrücke) NOVO Réf.090.864.10/0-10
070.501.00001	SW200	X	X	70.501	3025	SW100776	Amortisseur (antichoc) empierré, à chasser, à portée, de balancier, SOUS - (Platine) INCA Réf.090.173.20.000/0-0	Jewelled shock-absorber, shouldered, to press in, for balance, BOTTOM - (Main plate) INCA Réf.090.173.20.000/0-0	Stossicherung mit Stein, zum Einpressen, mit Auflage, für Unruh, UNTEN - (Werkplatte) INCA Réf.090.173.20.000/0-0
070.501.00002	SW200	X	X	70.501	3025	-	Amortisseur (antichoc) empierré, à chasser, à portée, de balancier, SOUS - (Platine) NOVO Réf.090.864.00/0-10	Jewelled shock-absorber, shouldered, to press in, for balance, BOTTOM - (Main plate) NOVO Réf.090.864.00/0-10	Stossicherung mit Stein, zum Einpressen, mit Auflage, für Unruh, UNTEN - (Werkplatte) NOVO Réf.090.864.00/0-10
040.380.00001	SW200-1	X	X	40.380	358	SW100673	Correcteur de raquette - (vis réglante)	Regulator corrector	Rückerkorrektor
040.200.00001	SW200-1	X	X	40.200	375	SW101161	Porte-pilon - Monté	Stud support - Assembled	Spiralkätzchen-Träger - Montiert
051.010.00031	SW400	X	X	51.010	401	SW105618	Tige de remontoir - longue (S1.2x24)	Winding stem - long (S1.2x24)	Aufzugwelle - lang (S1.2x24)
031.121.00001	SW200-1	X	X	31.121	407	SW101690	Pignon coulant	Sliding pinion	Kupplungstrieb
031.120.00001	SW200-1	X	X	31.120	410	SW101477	Pignon de remontoir	Winding pinion	Aufzugtrieb-Kupplungsrad
031.020.00001	SW200-1	X	X	31.020	415	SW101685	Rochet	Ratchet wheel	Sperrad
031.023.00001	SW200-1	X	X	31.023	420	SW101686	Roue de couronne	Crown wheel	Kronrad
051.120.00001	SW200-1	X	X	51.120	425-434	SW101721	Cliquet	Click	Klinke

Code article SELLITA	Nativité	Compatibilité		Code horloger	N° plan	Désignation	Designation	Bezeichnung
		SW200-1	SW400					
061.080.00001	SW200-1	X	X	61.080	SW101206	Ressort de cliquet	Click spring	Klinkenfeder
051.050.00001	SW200-1	X	X	51.050	SW101719	Bascule de pignon coulant	Yoke	Kupplungstriebebel
051.080.00001	SW200-1	X	X	51.080	SW101720	Tirette	Setting lever	Winkelhebel
051.090.00001	SW200-1	X	X	51.090	SW101236	Sautoir de tirette - 3 positions	Setting lever jumper - 3 positions	Winkelhebelraste - 3 Positionen
031.100.00001	SW200-1	X	X	31.100	SW101689	Renvoi - de mise à l'heure	Setting wheel	Zeigerstellrad
010.062.00001	SW200-1	X	X	10.062	SW101656	Pont du rouage de minuterie	Minute train bridge	Wechselradbrücke
030.040.00001	SW200	X	X	30.040	SW101517	Moblie d'échappement - Monté Nivarox	Escape wheel - Assembled Nivarox	Hemmungsrad - Montiert Nivarox
040.010.00001	SW200-1	X	X	40.010	1207.00	Ancre - Normale - Montée	Pallet fork - Standard - Assembled	Anker - Standard - Montiert
040.010.00004	SW200	X	X	40.010	1207.02	Ancre - Chrono - Montée	Pallet fork - Chrono - Assembled	Anker - Chrono - Montiert
040.050.00038	SW200	X	X	40.050	SW104971	Balancier annulaire, réglé - Nickel Doré - Régulé - Nivarox	Timed annular balance - Nickel Golden plated - Nivarox	Uhruh mit glattem Reif, reguliert - Nickel Vergoldet - Reguliert - Nivarox
040.050.00008	SW200	X	X	40.050	SW104973	Balancier annulaire, réglé - Glucydur Troux Borgnes réglé Nivarox	Timed annular balance	Uhruh mit glattem Reif, reguliert
093.011.00002	SW400	X	X	93.011	SW105310	Cercle d'agrandissement - Brut	Enlargement ring - Raw	Vergößerungsring - Roh
056.070.00001	SW200-1	X	X	56.070	SW101726	Lever stop	Stop lever	Stoppebel
088.542.00027	SW300-1	X	X	88.542	SW102576	Vis à tête conique 90° - plate, bout plat - S1.00 [235-100x105-160x50] - (2x vis de bride de fixation)	90° countersunk flat head screw, flat end - S1.00 [235-100x105-160x50] - (2x vis de bride de fixation)	90° mit Kegelnuppe - S1.00 [235-100x105-160x50] - (2x vis de bride de fixation)
088.515.00001	SW200-1	X	X	88.515	SW102172	Vis à tête cylindrique, renforcée, bombée, bout à pivot - S0.80 [177-80x135-160x35], de rochet (Pos 2)	Cylindrical reinforced convex head screw, pivot end - S0.80 [177-80x135-160x35], for ratchet wheel	Linsenzylinderschraube verstärkt mit Zapfen - S0.80 [177-80x135-160x35], für Sperrrad
088.506.00001	SW200-1	X	X	88.506	SW102180	Vis à tête cylindrique, bombée, bout plat - S0.80 [135-80x85-119x58], de pont inférieur (Pos.206)	Cylindrical convex head screw, flat end - S0.80 [135-80x85-119x58], automatic device lower bridge (Pos.206)	Linsenzylinderschraube mit Kegelnuppe - S0.80 [135-80x85-119x58], untere Brücke für Automatik
088.514.00001	SW200-1	X	X	88.514	SW102176	Vis à tête cylindrique, renforcée, bombée, bout plat - S0.80 [175-80x81-200x37], de roulement à bille (Pos.1)	Cylindrical reinforced convex head screw, flat end - S0.80 [175-80x81-200x37], ball bearing screw (Pos.1)	Linsenzylinderschraube verstärkt mit Kegelnuppe - S0.80 [175-80x81-200x37], Kugellagerschraube (Pos.1)
088.514.00002	SW200-1	X	X	88.514	SW102174	Vis à tête cylindrique, renforcée, bombée, bout plat - S1.00 [175-100x117-220x53] de fixation	Cylindrical reinforced convex head screw, flat end - S1.00 [175-100x117-220x53] case screw	Linsenzylinderschraube verstärkt mit Kegelnuppe - S1.00 [175-100x117-220x53] Schraube für Werkbefestigung
088.514.00003	SW200-1	X	X	88.514	SW102173	Vis à tête cylindrique, renforcée, bombée, bout plat - S0.80 [178-80x100-370x52], de couronne (Pos.200)	Cylindrical reinforced convex head screw, flat end - S0.80 [178-80x100-370x52], for crown wheel (Pos.200)	Linsenzylinderschraube verstärkt mit Kegelnuppe - S0.80 [178-80x100-370x52], Kronratschraube (Pos.200)
088.586.00001	SW200-1	X	X	88.586	SW102165	Vis à portée, tête bombée, bout plat - S0.80 [335-80x90-120x30-82x25] de bâti de dispositif automatique (x2 Pos.203-204)	Shouldered convex head screw, flat end - S0.80 [335-80x90-120x30-82x25] on automatic device mechanism (x2, Pos.203-204)	Linsensatzschraube mit Kegelnuppe - S0.80 [335-80x90-120x30-82x25] über Automatik-Mechanismus (x2, Pos.203-204)
088.546.00001	SW200-1	X	X	88.546	SW102167	Vis à tête conique 90° - bombée, bout plat - S0.80 [235-80x82-120x30], pt rouage (x2), balancier(x1), ancre(x1), barillet(x3)	90° countersunk convex head screw, flat end - train wheel bridge (x2), balance bridge (x1), pallet bridge (x1), barrel bridge	90° mit Kegelnuppe - räderwerkbrücke (x2), unruhbrücke (x1), ankerbrücke (x1), federhausbrücke (x3)
088.547.00001	SW200-1	X	X	88.547	SW102166	Vis à tête conique 90° - bombée, bout à pivot - S0.80 [237-80x123-140x27], plaque maintien indic.quant.(Pos.25), saut titr.(Pos.50)	90° countersunk convex head screw, pivot end - S0.80 [237-80x123-140x27], date jumper maintaining plate	90° mit Zapfen - S0.80 [237-80x123-140x27], Halteplatte für Datumraste

Code article SELLITA	Nativité	Compatibilité		Code horloger	N° plan	Désignation	Designation	Bezeichnung
		SW200-1	SW400					
088.587.00001	SW200-1	<input checked="" type="checkbox"/>	<input checked="" type="checkbox"/>	88.587 Nouveau	SW102164	Vis à portée tête bombée, bout à pivot - S0.80 [337-80x122-140x18-110x10], de pont de rouage de minuterie (Pos.51)	Shouldered convex head screw, pivot end - S0.80 [337-80x122-140x18-110x10], on minute train bridge (Pos.51)	Linseinsatzschraube mit Zapfen - S0.80 [337-80x122-140x18-110x10], über Wechselfradbrücke (Pos.51)
				5462 Ancien				

Fournitures – Bestandteile – Material

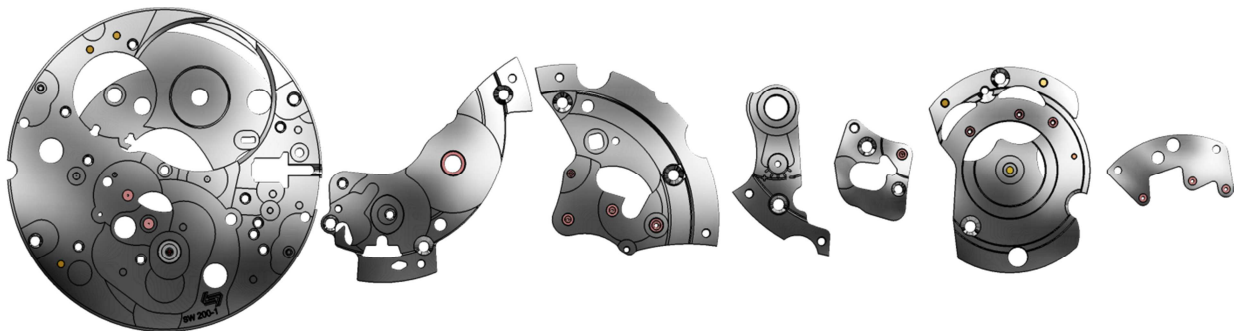

100

105

110

121

125

1134

1141



435

443

2570

445

462

2576

2595/1

425

430

9433



180/1

185

190

771

195

358

300

300/6

375

721/1

710



201/1

210

227

705

242

255

260

2556

2566

450

161



1497

1488

1530

1481

1482

415

420

407

410

3025

3024

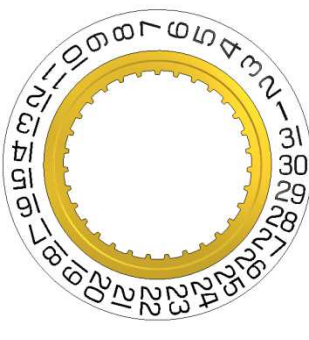

2557/1



926

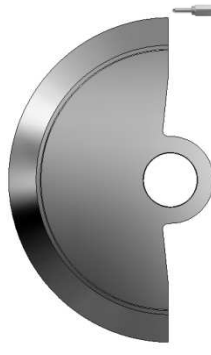

1143



401

144



51497



5415



51141



51134



5462



5420



5105



5445



5926



5110











5121



5125

Montage mouvement - Werkmontage - Assembling of the movement

Légende Huilage - Ölplan - Oiling lexical

Epilamé Epilamisiert Epilame-coated		
	Si les pièces à assembler ne sont pas neuves, les composants existants doivent être nettoyés et traités à la Moebius Fixodrop FK/BS 8941 avant le réassemblage.	
	Wenn keine neuen Teile montiert werden, müssen die vorhandenen Teile vor der Wiedermontage gewaschen und mit Moebius Fixodrop FK/BS 8941 epilamisiert werden.	
	If the pieces to be assembled are not new, existing components must be cleaned and treated with Fixodrop FK/BS 8941 Epilame before reassembly.	
Lubrification Schmierung Lubrication		
	Huile fine Dünnflüssiges Öl Fine oil	Moebius 9010
	Huile épaisse ou graisse Dickflüssiges Öl oder Fett Thick oil or grease	Moebius HP-1300 ou - oder - or Moebius D5
	Huile spéciale pour levées Spezialöl für Hebungssteine Special oil for pallet stones	Moebius 941 ou - oder - or Moebius 9415
	Graisse Fett Grease	Moebius 9501 ou - oder - or Jismaa 124
	Graisse Fett Grease	Klüber P125
Moebius Fixodrop FK/BS 8941		
	Produit très volatile ! À garder après usage dans des récipients fermés et étanches.	
	Sehr flüchtiges Produkt ! Nach Gebrauch in geschlossenen und luftdichten Behältern aufbewahren	
	Very volatile product! To keep after usage in closed and airtight containers.	
Pré-lubrification Tauchschmierung Splash lubrication		
	Ne pas laver. Si la pièce est très sale ou rouillée, l'échanger par une fourniture d'origine livrée pré lubrifiée par SELLITA SA.	
	Nicht waschen. Sollte das Stück sehr verschmutzt oder rostig sein, ist es gegen ein von SELLITA SA vorgeöltes Original-Stück zu tauschen.	
	Do not wash. If the part is very dirty or rusty, it should be exchanged for an original part which is lubricated and delivered by SELLITA SA.	

Couples donnés- einzuhaltende Drehmomenten - given torques

Les couples sont indiqués à la valeur minimum pour dévisser.

Die Drehmomente werden als minimale Lösemomente angegeben.

The torques are indicated at the minimum value for loosening.

Mécanisme de mise à l'heure - Zeigerwerkmechanismus - Hand setting mechanism

Ordre d'assemblage
Montagereihenfolge
Order of assembly

- | |
|------|
| 100 |
| 407 |
| 410 |
| 401 |
| 2570 |
| 443 |
| 435 |
| 445 |
| 5445 |

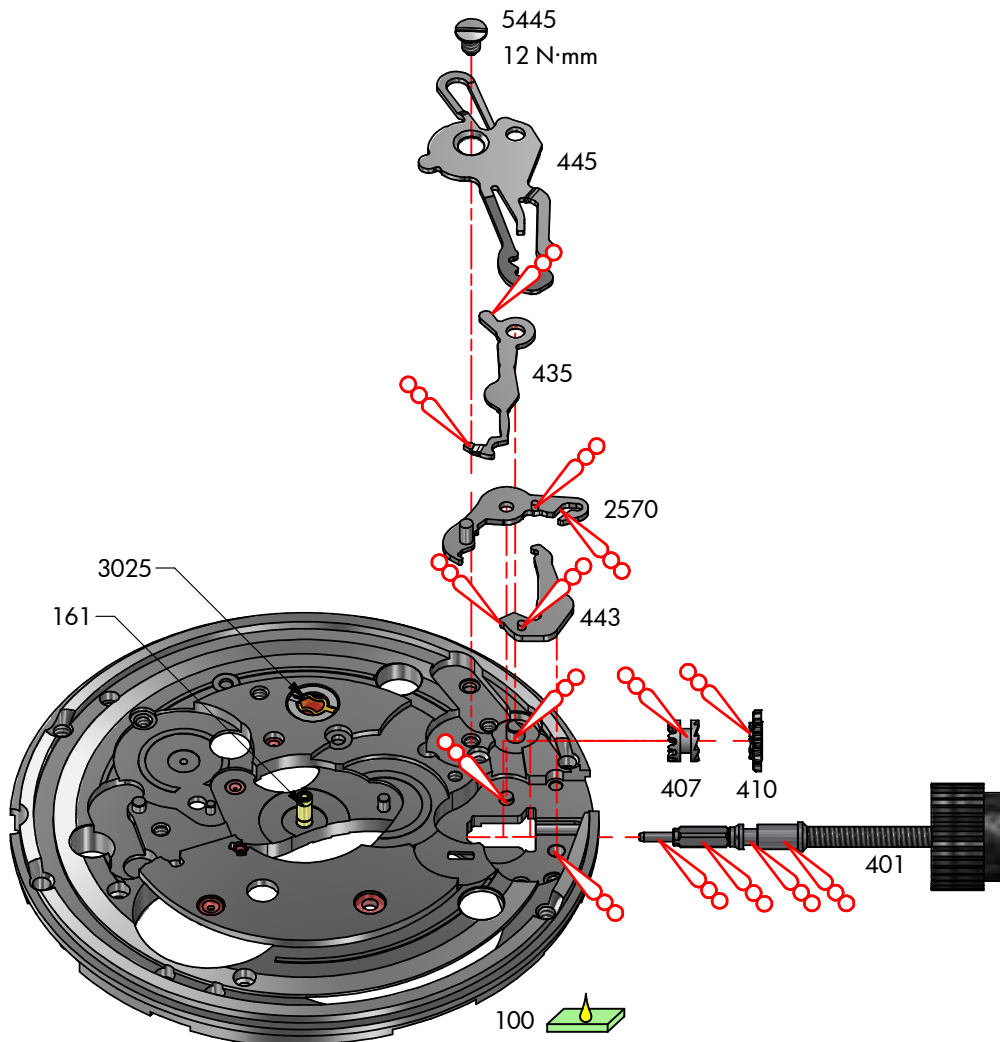

Mouvement de base - Basiswerk - Basic movement

Ordre d'assemblage
Montagereihenfolge
Order of assembly
201/1
705
210
227
110
5110 (2x)
180
9433
105
5105 (3x)
420
5420
425
430
415
5415
710
125
5125
121
5121

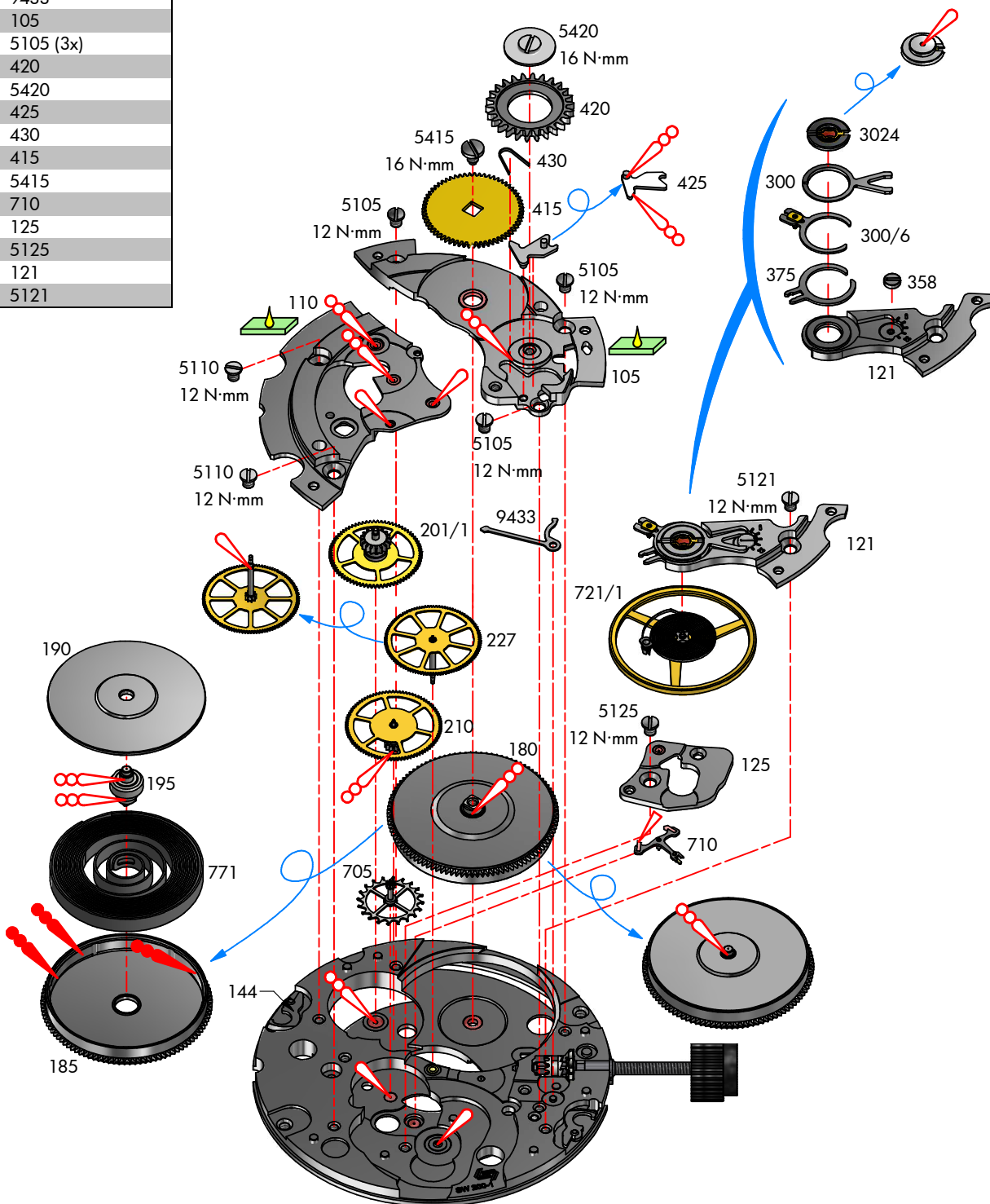

Ordre d'assemblage
Montagereihenfolge
Order of assembly

926
5926 (2x)
1134
1482
1530
1488
1481
1141
51141
1134
51134
1143/1
51497

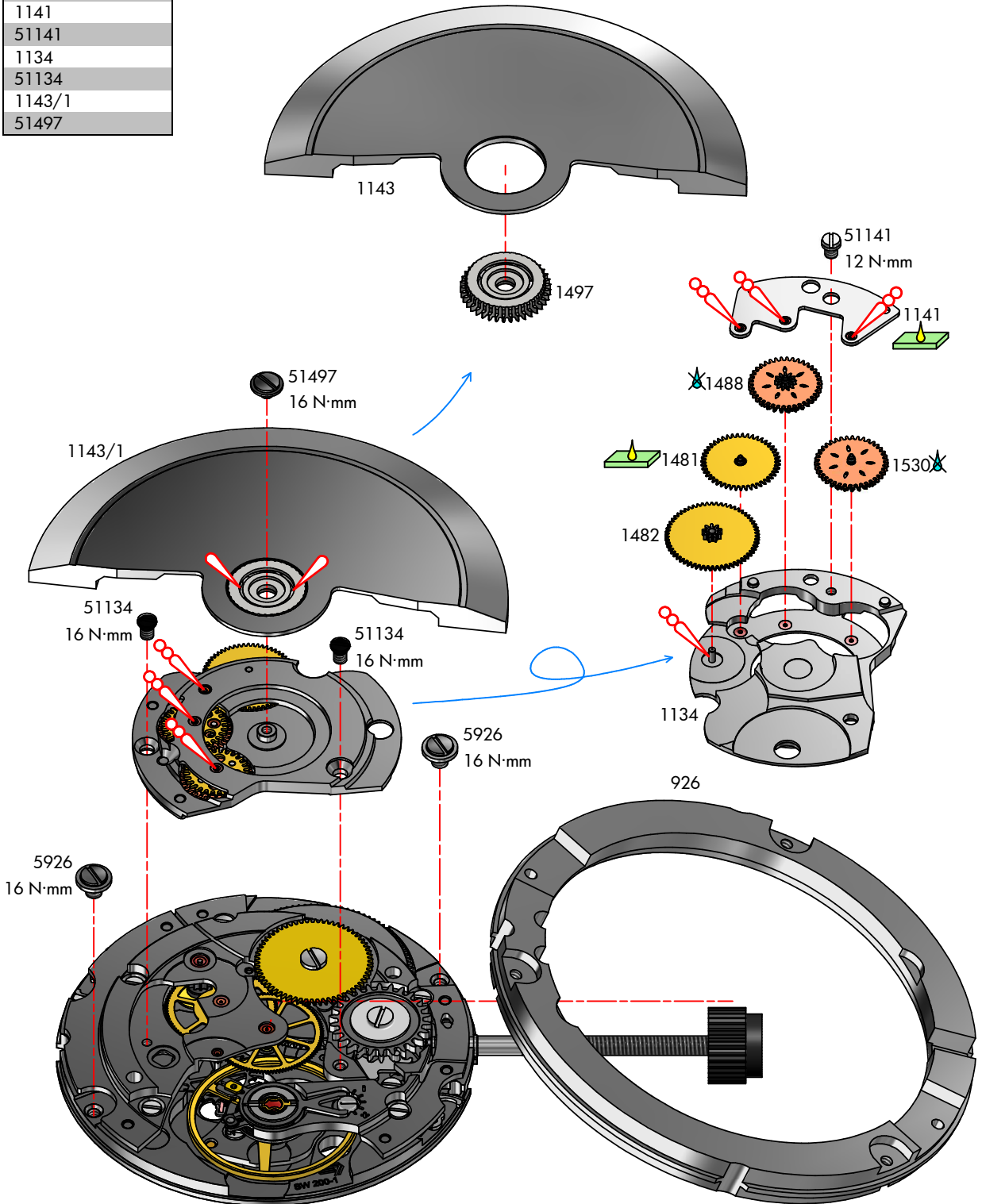

Mécanisme de calendrier et de compteur d'heures - Kalender-und Stundenzählermechanismus - Date and hour counter mechanism

Ordre d'assemblage Montagereihenfolge Order of assembly
242
260
450
2566
2557/1
462
5462
2556
2576
2595/1
52595
255

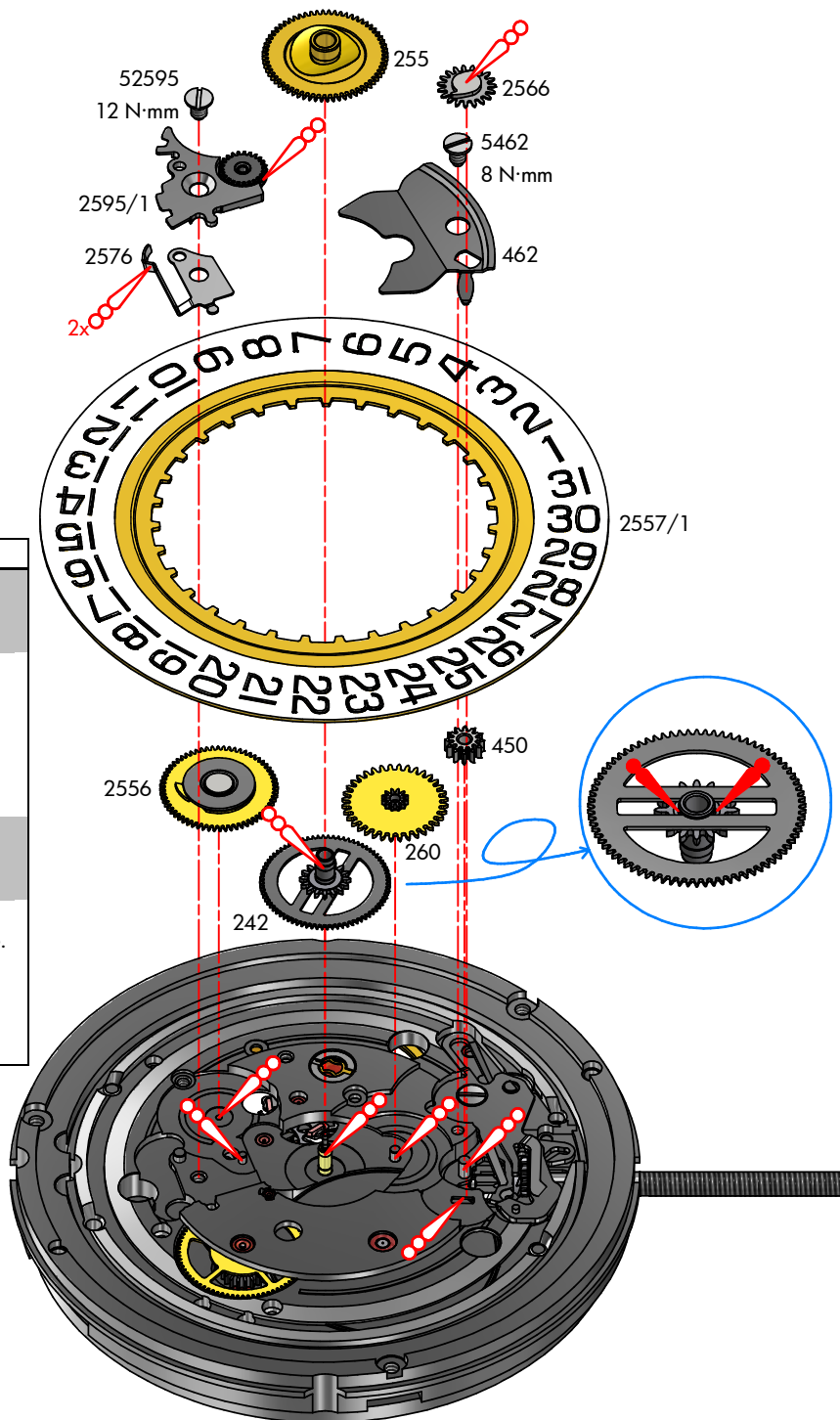

2576

Lubrifier la pièce 2576.
Teil 2576 schmieren.
Lubricate part 2576.

Tourner la pièce 2557/1 d'environ 10 dents avec la correction rapide.
Teil 2557/1 mit Schnellkorrektur ca. 10 Zähne drehen.
Rotate part 2557/1 approx 10 teeth with rapide correction.

Lubrifier à nouveau la pièce 2576.
Teil 2576 nochmals schmieren.
Lubricate again part 2576.

Tourner à nouveau la pièce 2557/1 d'env. 10 dents avec la correction rapide.
Teil 2557/1 nochmals mit Schnellkorrektur ca. 10 Zähne drehen.
Rotate part 2557/1 approx 10 teeth with rapide correction again.

Habillage - Fabrikanten – Manufacturirin

Informations générales	Allgemeine Informationen	General information
Le cadran est maintenu par 2 fixateurs de cadran.	Das Zifferblatt ist durch 2 Zifferblatthalter gehalten.	The dial is fixed by means of 2 dial fasteners.
Fixation du mouvement par 3 brides d'emboîtement.	Werkbefestigung durch 3 Befestigungsplättchen.	Movement fixed by 3 casing clamps.
Cadran plat avec trou de centre Ø 2,00 mm.	Flaches Zifferblatt mit Zentrumloch Ø 2,00 mm.	Flat dial with centre hole Ø 2,00 mm.
Cercle d'agrandissement autour de la platine, maintenu par 2 vis de fixation.	Vergrößerungsring rund die Werkplatte, durch 2 Fixierungsschrauben befestigt.	Enlargement ring around the main plate, maintained by 2 fixing screws.

Déboîtement	Ausschalen	Taking the movement out of the case
Enlever les vis et les brides d'emboîtement.	Die Schrauben und die Befestigung Plättchen wegnehmen.	Remove the screws and the casing clamps.
Enlever les aiguilles, écarter les 2 verrous et retirer le cadran (voir figure ci-dessous).	Zeiger entfernen und nach dem Entriegeln, Zifferblatt entfernen (siehe nachstehende Abb.).	Remove the hands, push the two bolts aside (see figure below) and remove the dial.
Au travers de l'ouverture prévue sur le pont, presser sur l'axe de tirette puis dégager la tige de remontoir.	Aufzugswelle entfernen, indem durch die auf der Brücke vorgesehene Öffnung auf die Winkelhebelwelle gedrückt wird.	Release the winding stem by pressing the setting lever axle through the opening provided in the bridge.

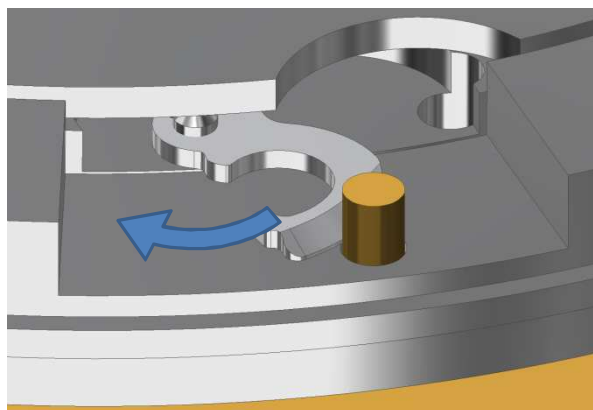

Cage pour boîte - Uhrwerkgestell für Gehäuse - Frame for case

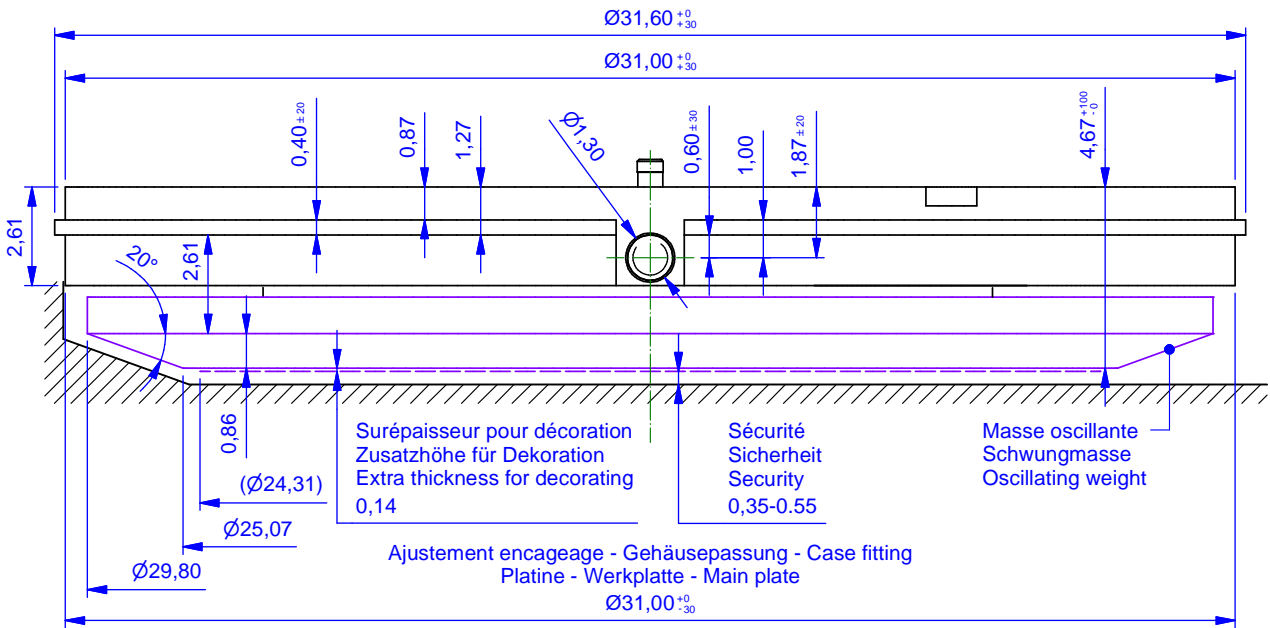

Distance au centre du mouvement, à vérifier avant l'emboitage de la série
 Distanz zum Werkzentrum, vor dem Einschalen der Serie prüfen
 Distance to movement center, check before casing of the serie

Course de la tige
 Weg der Stellwelle
 Length of travel of stem

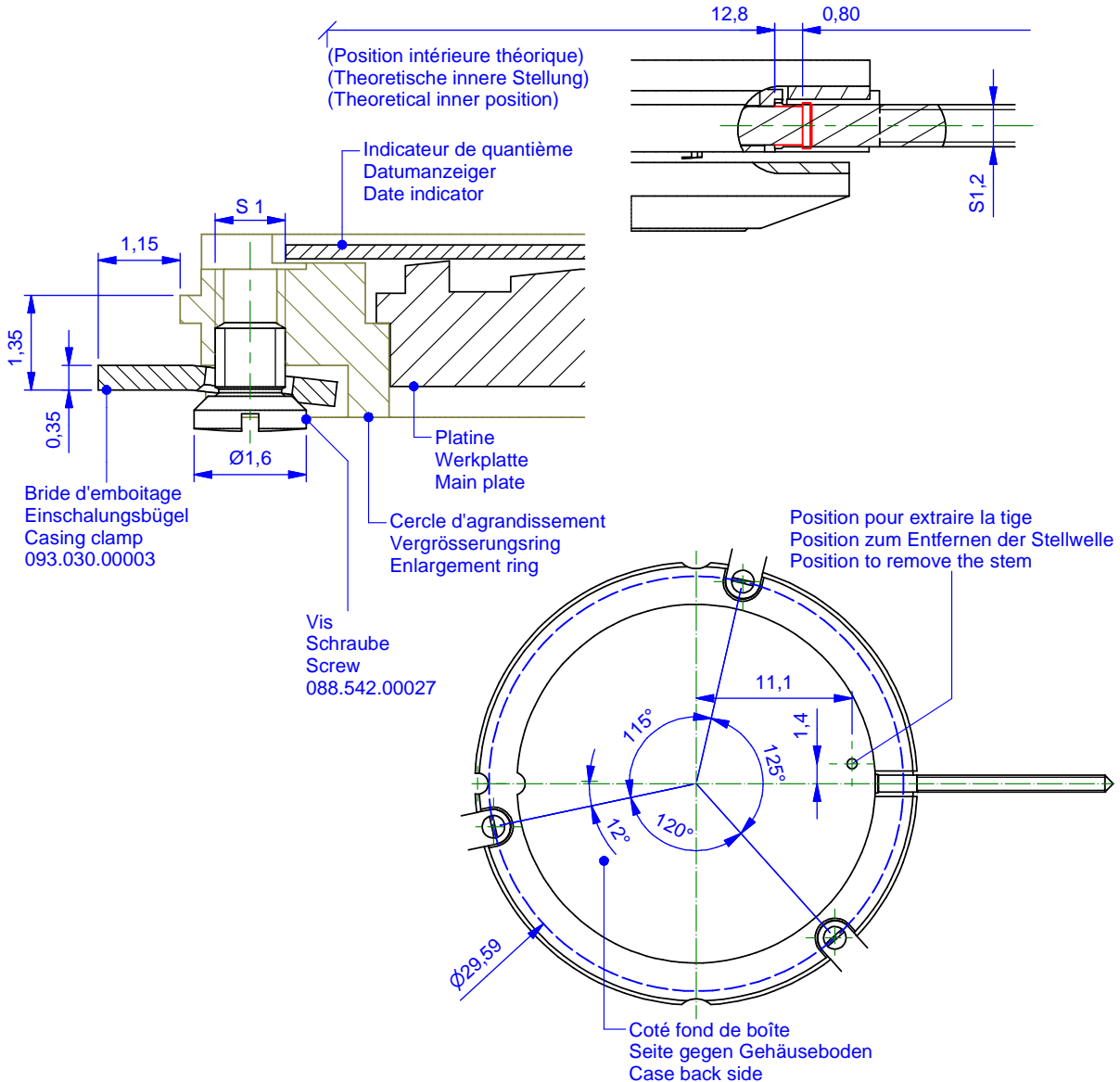

Indications pour cadran - Angaben für Zifferblatt - Indications for Dial

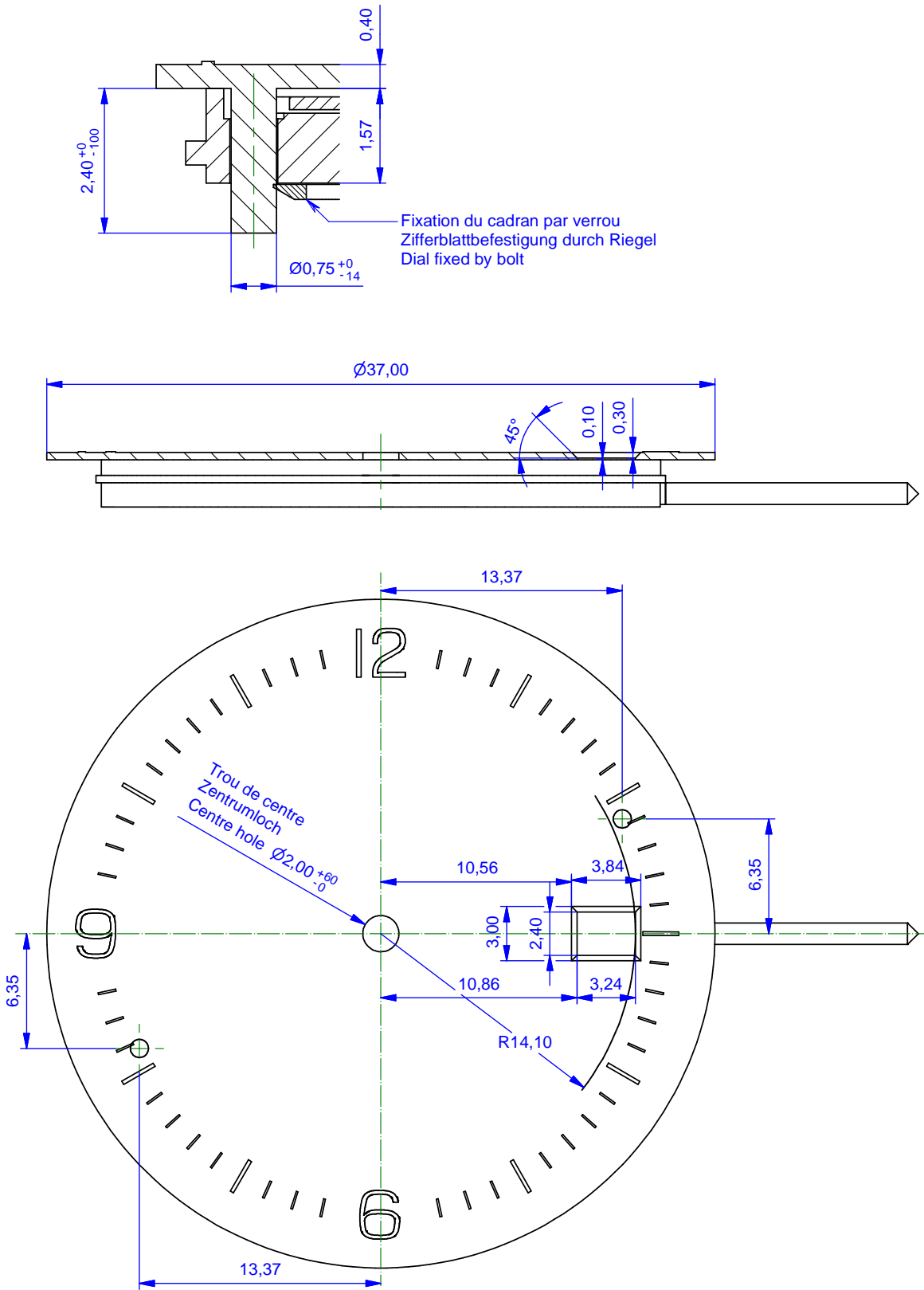

Indicateur de quantième - Datumanzeiger - Date indicator

Vernissage/Décalque, uniquement sur cette surface (hauteur max. des couches 0.03 mm)
 Grundierung/Bedruckung, nur auf diese Oberfläche (max. Dicke der Farbschichten 0.03 mm)
 Varnishing/Printing, only on this surface (max. thickness of layers 0.03 mm)

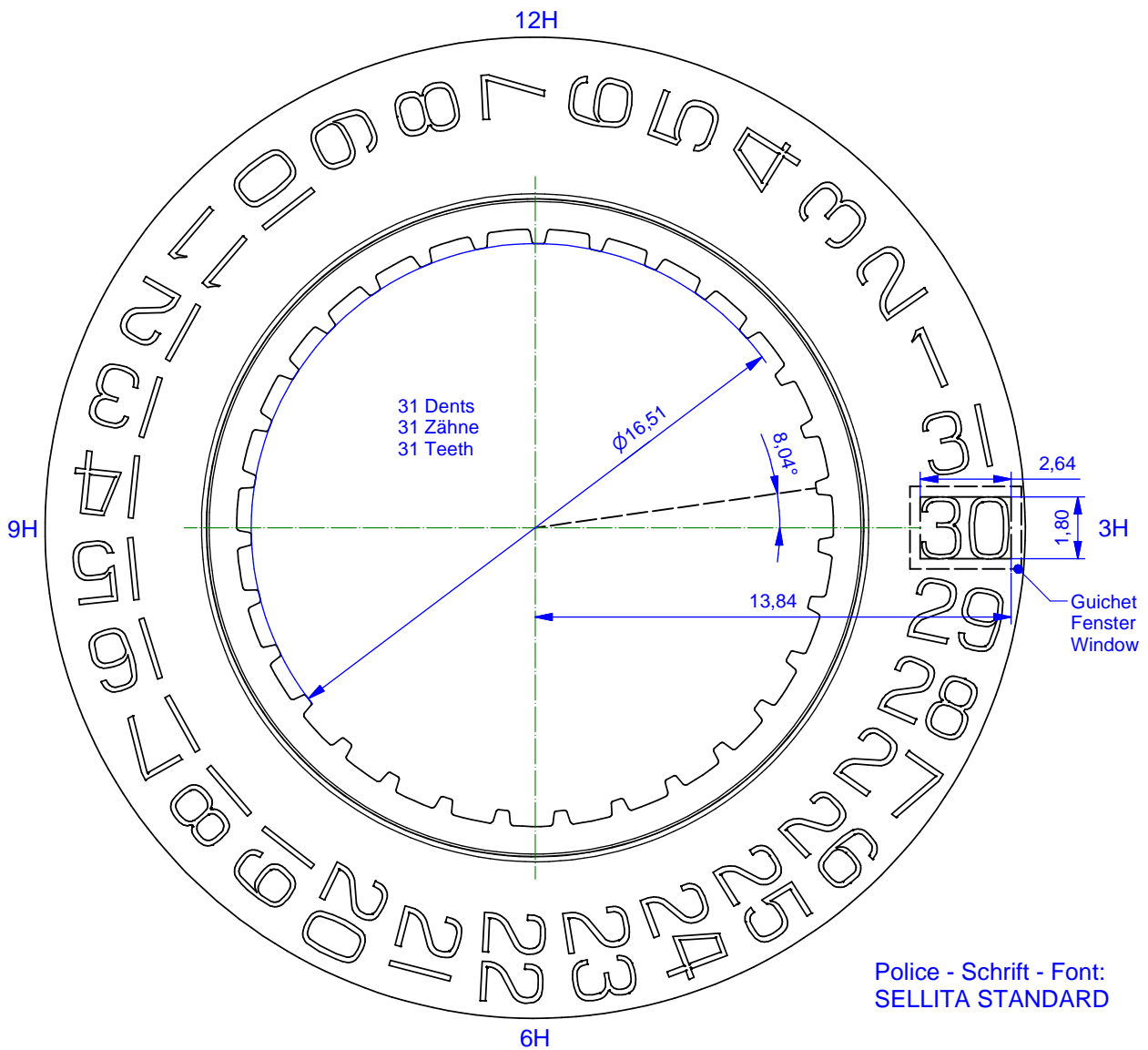
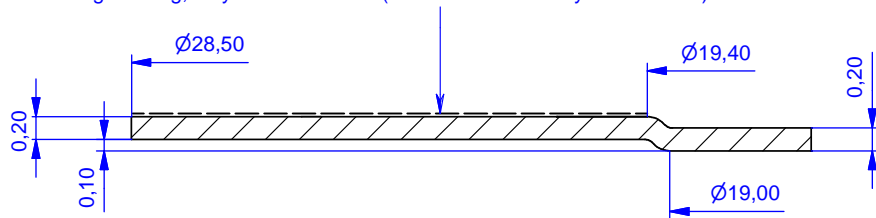

Aiguillages - Zeigerwerkhöhen - Hand fitting heights

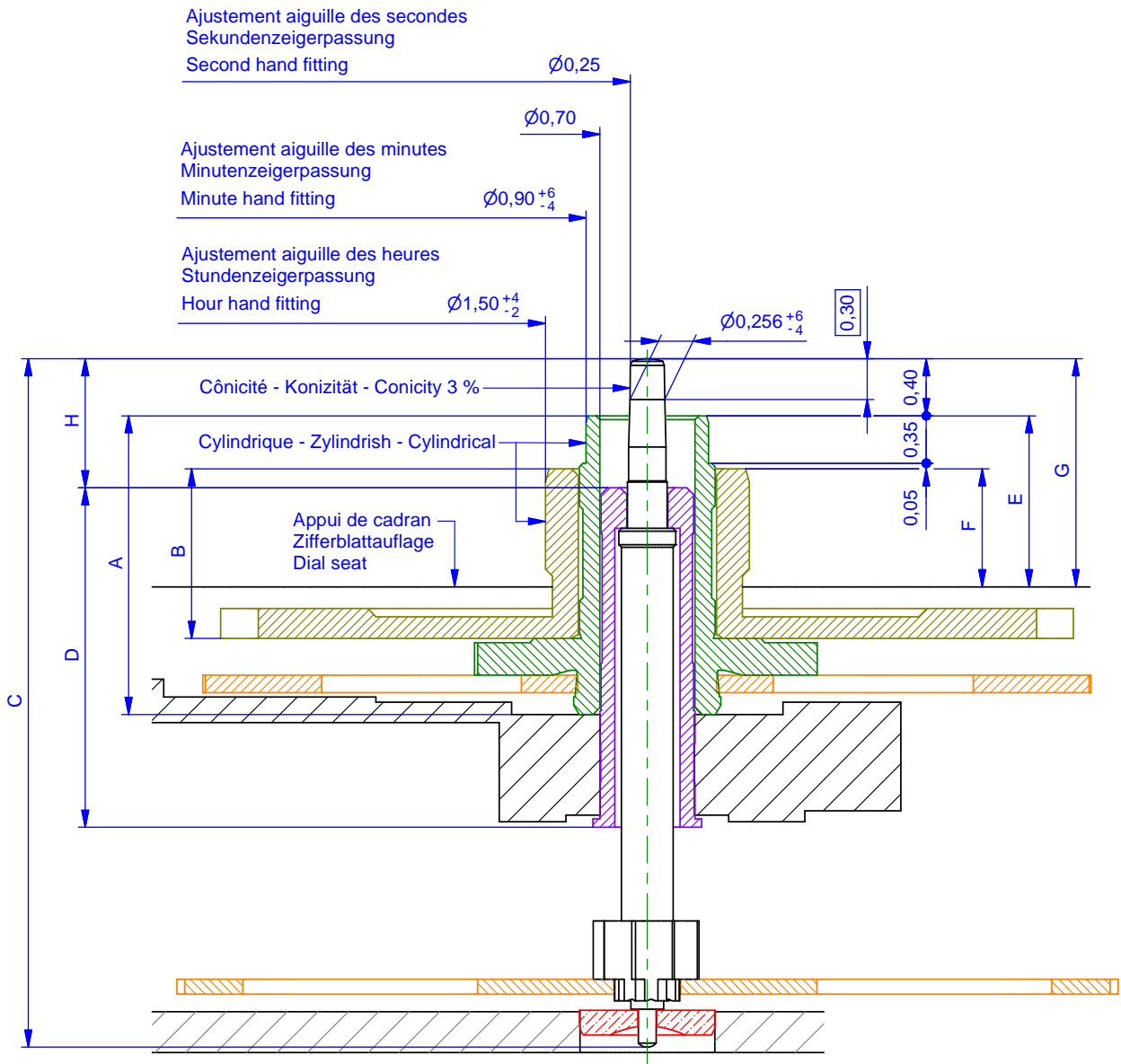

N°	Longueur - Länge - Length [mm]				Dépassement - Höhe - Height [mm]			
	A	B	C	D	E	F	G	H
2 (standard)	2.20	1.25	5.07	2.50	1.28	0.88	1.68	0.95
3	2.45	1.50	5.32	2.50	1.53	1.13	1.93	1.20
4	2.70	1.75	5.57	2.50	1.78	1.38	2.18	1.45
5	2.95	2.00	5.82	2.50	2.03	1.63	2.43	1.70
6	3.20	2.25	6.07	2.50	2.28	1.88	2.68	1.95

Longueur de tige et position de couronne - Länge des Stellwelle und Kronenposition - Length of setting stem and crown position

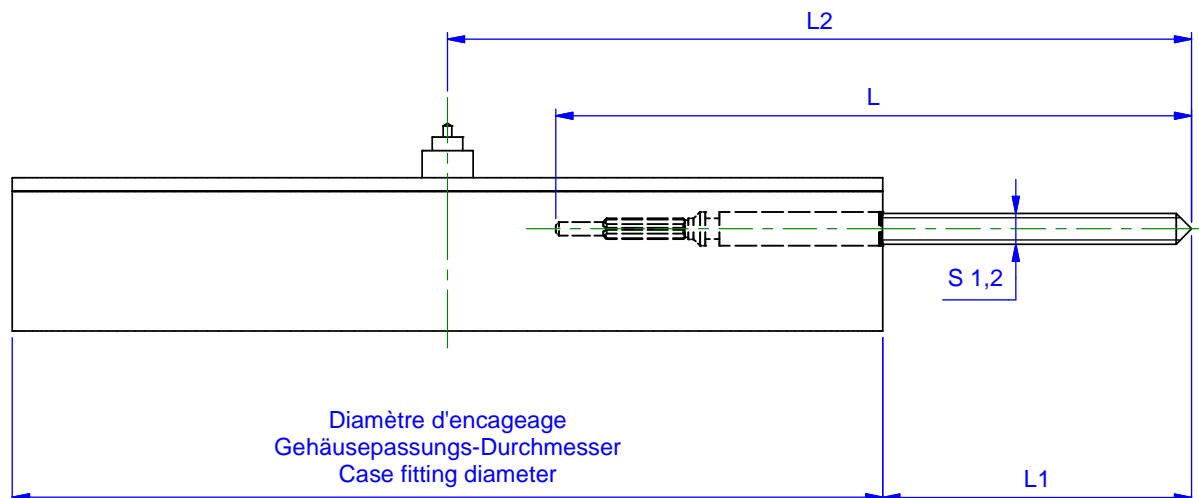

Longueur de la tige Länge des Stellwelle Length of setting stem	L	L1	L2
Longue Lang Long	24.00	14.00	29.50

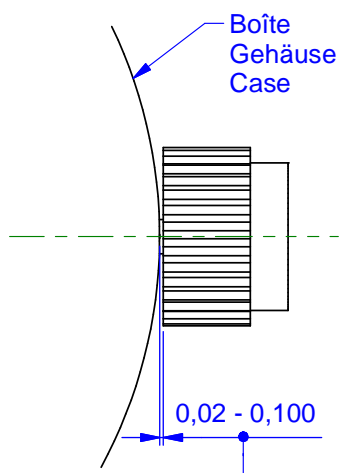

Afin d'éviter des dégâts importants au mouvement lors de chocs accidentels sur la couronne de remontoir, il est nécessaire de contrôler lors de l'emboîtement que l'espace entre la couronne et la carrure soit de 0,10 mm au maximum.
Zur Vermeidung von Schäden am Werk infolge von zufälligen Schlägen auf die Krone der Aufzugwelle muß beim Werkeinbau der Abstand zwischen Krone und Gehäusemittelteil überprüft werden, er darf höchstens 0,10 mm betragen.
To prevent major damage to the movement if the winding stem crown is inadvertently knocked, it is necessary to make sure that the gap between the crown and the middle is no more than 0.10 mm when fixing the movement in its case.

Couronne vissée: positions – Geschraubte Krone: Stellungen – Screwed crown: positions

Force du ressort
Federkraft
Force of spring

max. 13N

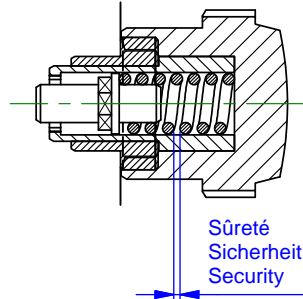

Fonction
Funktion
Function

Couronne vissée
Krone zugeschraubt
Crown tightened

Sûreté
Sicherheit
Security

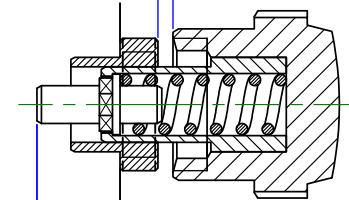

Remonter
Aufziehen
Wind up

Course de la tige Weg der Stellwelle Travel of setting stem	
C	0.80
C1	0.30
C2	0.50

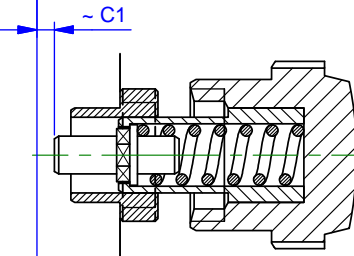

Correction de la date
Datum einstellen
Adjust date

$C = C1 + C2$

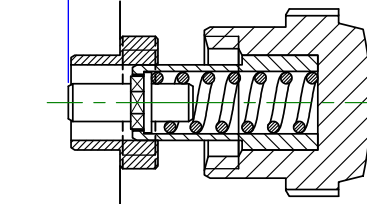

Mise à l'heure
Zeiger stellen
Adjust time

min. 9N

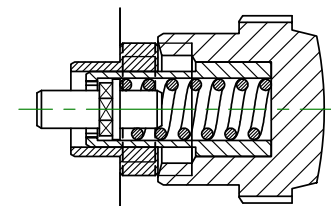

Position neutre
Neutrale Stellung
Neutral position

به سفارش دقت زمان تهران

Cette page est laissée vide intentionnellement en cas d'impression recto-verso.

Diese Seite wird absichtlich leer gelassen für den Fall, dass doppelseitig gedruckt wird.

This page has deliberately been left blank in case of double sided printing

Ce document est disponible sur :
Dieses Dokument finden Sie auf der Seite von:
This document is available on:

